



TAKUMI

UC Series



5-Axis Vertical Machining Center

UC250x

UC320x

## 02 Product Preview

### Basic Information

- 03 Frame
- 04 Spindle
- 05 Feed Axis
- 06 Rotary Table

### Machine Information

- 07 User Convenience
- 08 Takumi PC Console
- 11 Diagrams
- 13 Machine Specification
- 14 Standard/ Optional

# CONTENTS

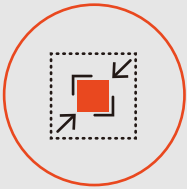

### Large working area in a small footprint

With a footprint of 5.7m<sup>2</sup> (UC250.x), the UC Series is the most compact machine in its class on the market.



### High rigidity LM roller guideways

The UC Series are equipped with Ø45 mm wide LM roller guideways, which features higher load capacity and greater rigidity even at high acceleration.



### Superior surface finish

Intelligent Spindle Thermal Compensation (*i*Spin I™) controls the heat generated during machining. The predictable spindle growth will be automatically compensated for the temperature changes and guarantees a high precision cutting performance.

# UC Series

The Takumi UC Series 5-axis vertical machining center are designed for high precision finishing of small and medium size part in market such as dynamic die and mold, automotive, aerospace, medical applications and job shops. In a compact footprint, the UC series can accommodate workpieces up to 430mm in length and 200kg in weight.

The UC Series has an extremely robust structure to ensure enough stiffness to perform semi-finishing and finishing and offer the ideal dynamic, speed and acceleration at a competitive price.



Takumi console operation panel with 15-inch touch screen and dual screen (optional).

### Robust one-piece casting bed

Integrated bed frame ensures high rigidity and excellent vibration absorption compare with separate structure providing excellent surface finishes. The base width provides stability for large table loads and the increased weight absorbs the inertia of high rapids and fast cutting speeds.



### High rigidity structure

Bed, columns, saddle and other main castings are made of Meehanite grade cast iron and remove the internal stress by heat treatment to ensure the best structural stability and positioning accuracy.

### Hand scraping

Accuracy is ensured by hand scraped contact points. Contact surfaces such as column to base components, spindle cartridge to spindle housing, ball screw bearing block seats to bearing retainer and worktable to linear guide trucks and motor seat.

Hand scraping results in better mating surfaces of key components and will provide consistent results over a longer period of time.



01

UC Series  
Frame

# UC Series Spindle 02

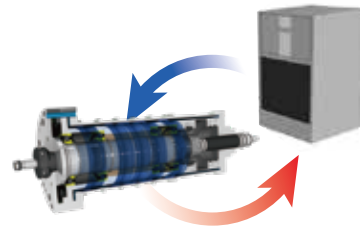
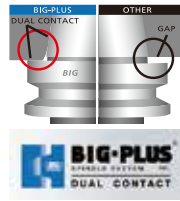

### High speed direct drive spindle

The high-power direct drive spindle limits vibration, noise and power loss during high speed rotations to achieve superior part finish.

### Dual surface contact design

The BIG-PLUS spindle system ensures superior finish thanks to simultaneous fit of taper and flange spindle.

### Stable Spindle Cooling Circulation option

Spindle temperature is constantly controlled by oil chiller. Our test results have proven that the temperature of the circulating oil is controlled within certain variation which minimizes thermal displacement during continuous operation at high speed.

## Spindle Power - Torque Curve

### 15,000rpm Direct drive spindle

(Spindle motor: Fanuc w/o CTS)

**9/15 kW**  
Power (Cont./S3-25%)

**57.3/119 N.m**  
Torque (Cont./S3-25%)

### 15,000rpm Direct drive spindle

(Spindle motor: Heidenhain with, w/o CTS)

**10/14 kW**  
Power (Cont./S6-40%)

**63.7/89.4 N.m**  
Torque (Cont./S6-40%)

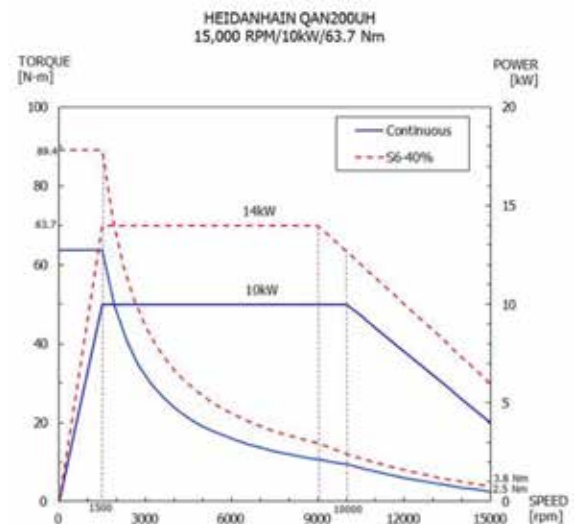
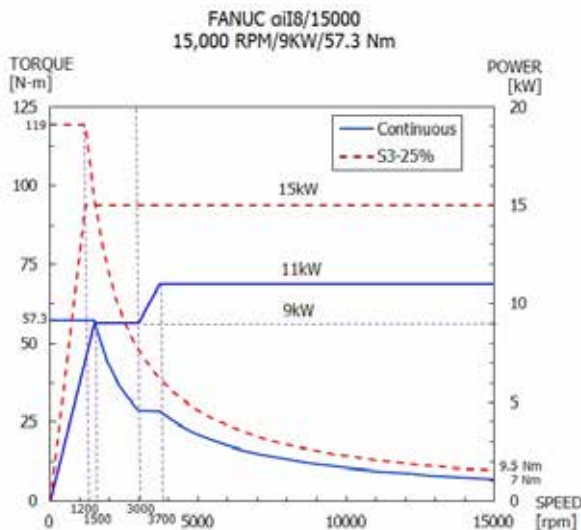

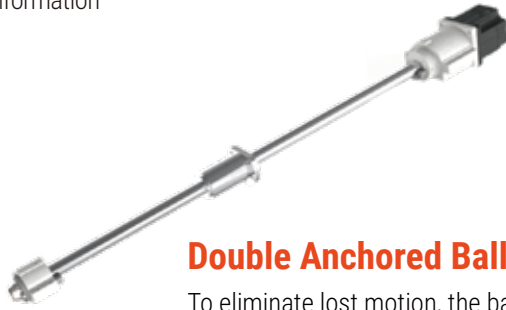

### Double Anchored Ballscrew

To eliminate lost motion, the ballscrews are anchored on both ends and pre-tensioned. The motors are directly coupled to the ballscrews.

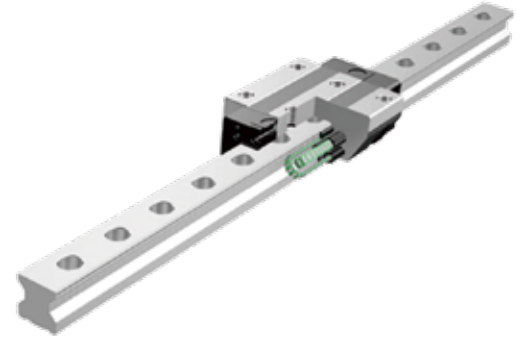

### Roller Type LM Guide

The new UC Series (UC320.x) are equipped with Ø45 mm wide LM roller guideways. These features higher load capacity and greater rigidity even at high acceleration. Additionally, they have greater contact area to support faster feeds, higher rigidity and higher weight bearing capability.

### Premium Ballscrews

UC Series are equipped with high precision ballscrews, featuring high load capacity while also providing high durability and rigidity during heavy duty cutting.



### High-Accuracy Linear Scales option

Linear scales are optional on all 3 axes. Mounted to the table, cross rail and head they take a direct reading of the true position of the axis. This compensates for thermal growth, mechanical flex and backlash, for improved accuracy and repeatability during the life of the machine.

# 03 UC Series Feed Axis

# UC Series Rotary Table

# 04

## High Performance Rotary Table

The UC Series has a tilting rotary table which is designed to present high performance in high speed machining. The table is having high mechanical strength with worm shaft and worm wheel design which ensures superior accuracy and fine surface finishes.

- UC250x A/C rotation range: **+30° ~ -120°/360°**
- UC320x A/C rotation range: **+30° ~ -120°/360°**
- UC250x A/C rotation speed: **25/25 rpm**
- UC320x A/C rotation speed: **16.7/22.2 rpm**

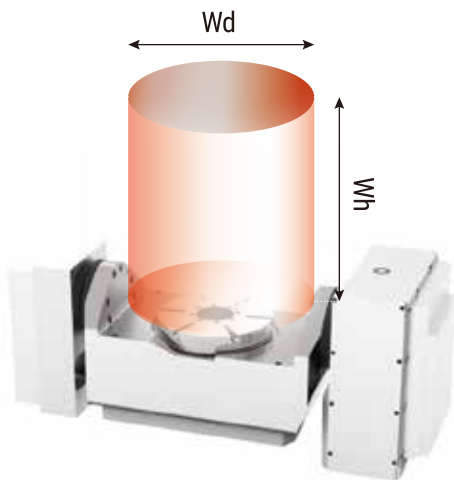
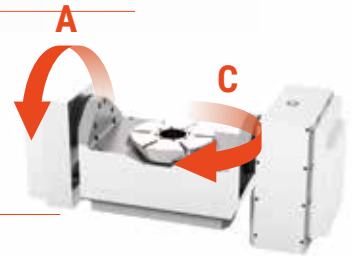

### Maximum workpiece size (Wd x Wh)

UC250x	Φ 310 x 250mm
UC320x	Φ 430 x 300mm

### Maximum workpiece weight

UC250x	100kg
UC320x	200kg

## A/C-Axis Rotary Encoder as Standard

Both axes are equipped with Heidenhain rotary encoders for precise  $\pm 5$  arc-second positioning accuracy.

The rotary axes deliver twice the accuracy of competitive machines to achieve greater accuracy performance when machining away from the center of rotation.



## Ergonomic Design

Shorter access to the table make setup work such as fixture adjustment and maintenance easy.

- Distance to the center of the table:

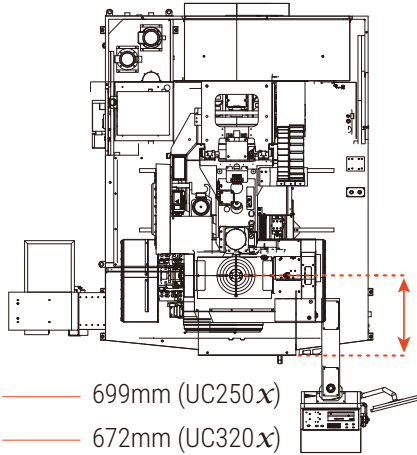

- Distance from floor surface to pallet surface:

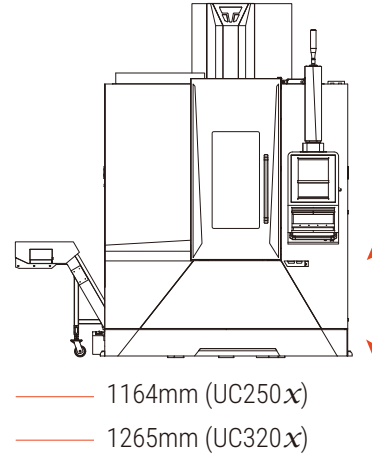

## Ergonomic Swivel Operation Panel

The operation panel can swivel 90°, and the height is designed to be at the operator's viewpoint.



## Effective Chip Removal Solutions

High pressure coolant through spindle and other chip removal solutions help wash away chips from hole drilling, tapping and other machining in the cavity. In addition, machining points can be cooled and extend the life of the tool.



30 bar coolant through spindle



Spindle air blast

## Large Door Opening

Large door opening to the working area gives the operator impressive freedom and handling space.



**UC Series**  
**User Convenience**

**05**



# 06 UC Series Powerful Takumi PC Console

The powerful, cutting-edge operation system, Takumi PC console, ensures optimal efficiency and productivity with a variety of intelligent functions. It brings your machining operation experience to the next level by integrating Window 10 PC with Fanuc CNC system on a 15-inch touch screen.



Takumi console operation panel with 15-inch touch screen and dual screen (optional).

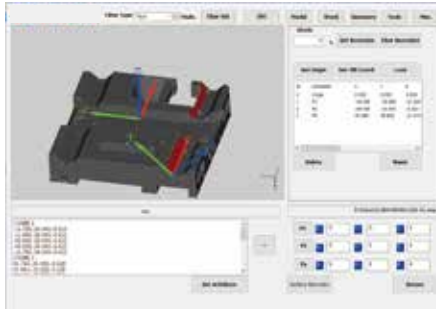

### User-friendly Programming

Visualize workpieces by inputting 3D model.

- Support 3D IGS/STEP or 2D DXF file input. DXF files can be directly opened on the CNC and transferred to the CNC program at a simple click.
- Conversational Event Based Programming allows making part programs by simply choosing machining events and configuring its parameters, without having to write G-Code.

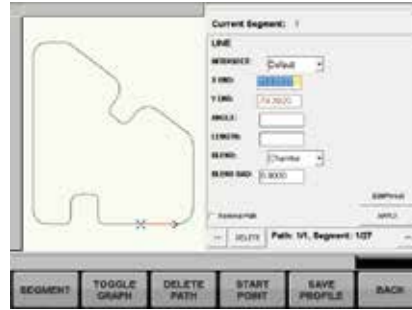

### Smart Profile Editor

Create contour intuitively.

- Quick and simple path creation of geometric profile. Enhance efficiency by automatic calculation of drawing the contour. (E.g. The connection between line and circular arc)

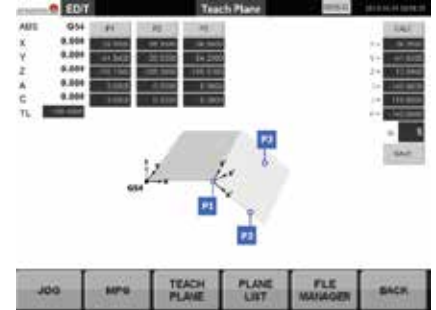

### Easy Tilted Plane Programming

More efficient machining experience with built-in events.

- Set work plane origin by manual Input, Teach, or 3D Model Import to program a tilted plane part easily.

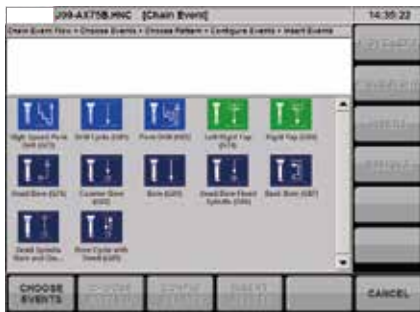

### Built-In Events

Built-in events function keeps unproductive times to an absolute minimum.

- Built-in event includes standard drill, bore, tap, contour, pocket, helix, pattern, setup, and auxiliary events.

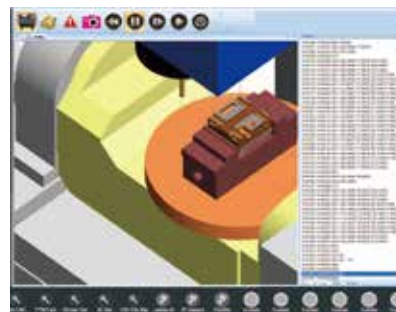

### 5-Axis Simulation

Realistic simulation for reliable production process.

- Realistic simulation enables verification of the NC program before machining.
- Prevention of machine collision and downtime.

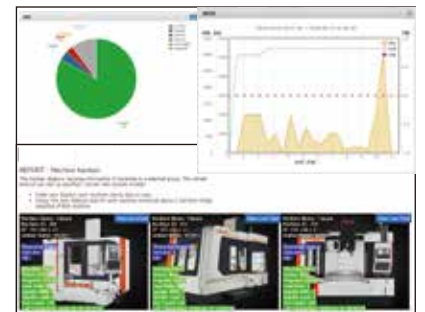

### Realization of Machine Monitoring

Higher machine utilization thanks to machine monitoring.

- Status display of machine data and its analysis can be used to minimize machine down-time.
- Provides 4G and network interfaces to collect machine data for dashboards or ERP/MES systems. Supports MTConnect, OPC/UA, FTP, HTTP, or WebSocket Web services.



### Window and FANUC System

Win10 PC System compatible with FANUC CNC and other CNC Sub-Systems.



### Simulation Preview

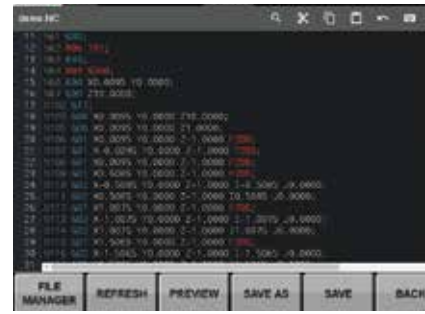

### G-Code Editor

- Seamless Integration of Win10 PC with FANUC CNC system, combining user-friendly operation, custom apps, and control accuracy.
- Allows visual inspection of generated tool paths and final dimensions.
- Enables ISO/EIA G-Code editing for writing standard G-Code part programs or to fine tune CAD/CAM posts.



### Job Scheduler

Higer utilization by automatically switch to the next job schedule.



### Tool Life Management

Smooth tool life management.

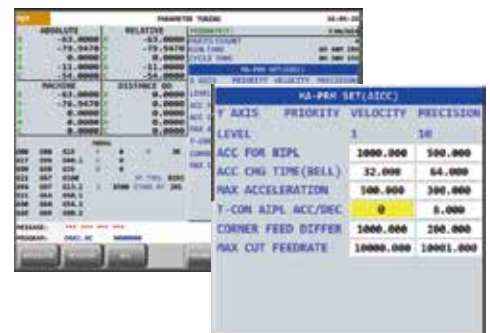

### High-Speed and High-Precision Setting

- Use job-folder and files to manage the production sequence. The job-folder contains NC program, SOP, and production quantity. Once the machine completes the production quantity, it automatically switches to the next job schedule.
- Provide management tool to manage the tool type, size, life and location (Machine magazine or Inventory). System automatically captures the number and the life of the tool.
- Provide simplified parameters and quickly setting for different machining conditionend.

# External Dimension

## UC250x

Unit : mm

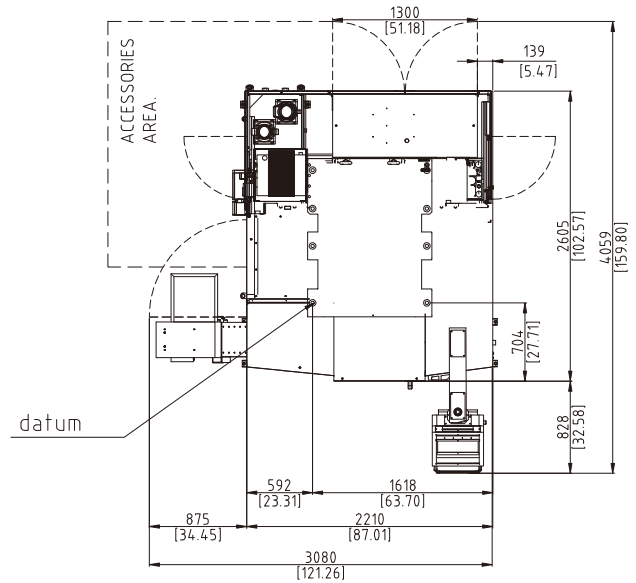
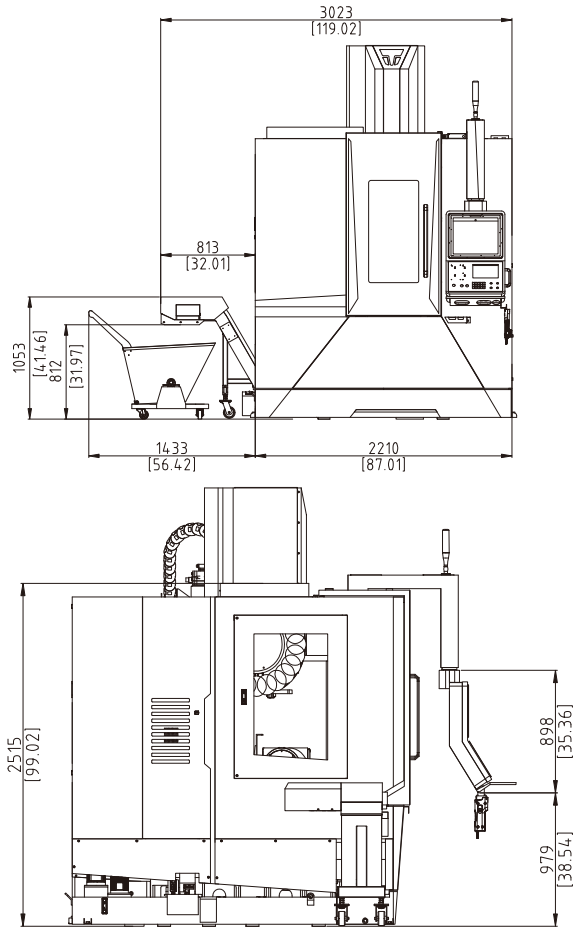

## UC320x

Unit : mm

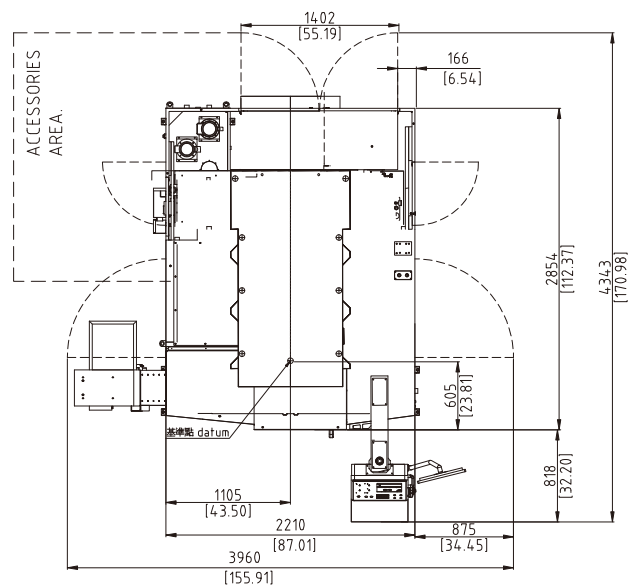
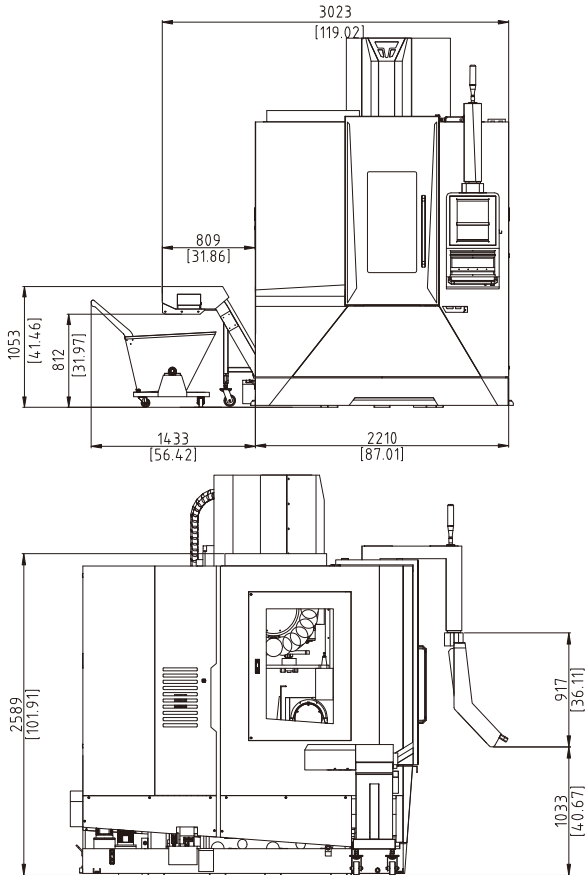

# Table & T-Slot Dimension

Unit : mm

UC250x

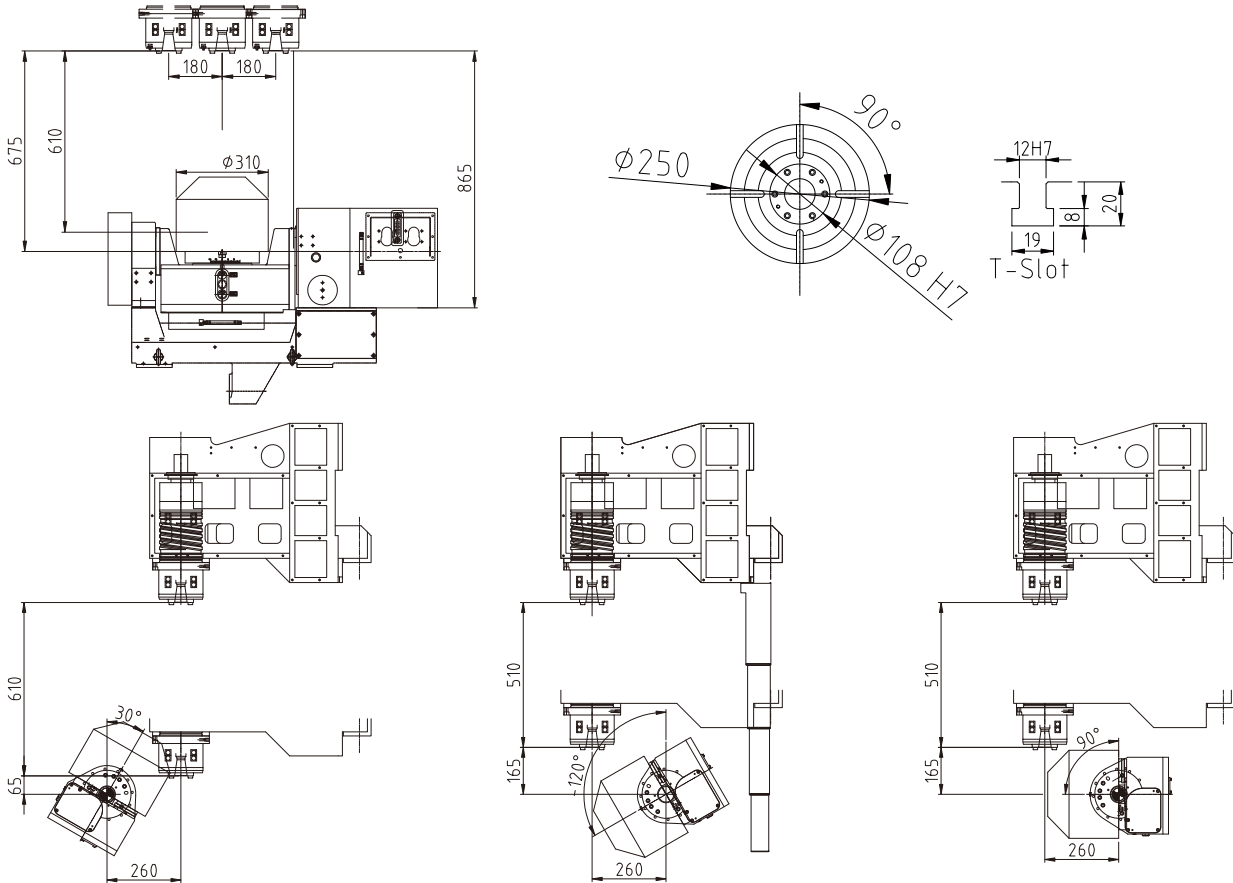

Unit : mm

UC320x

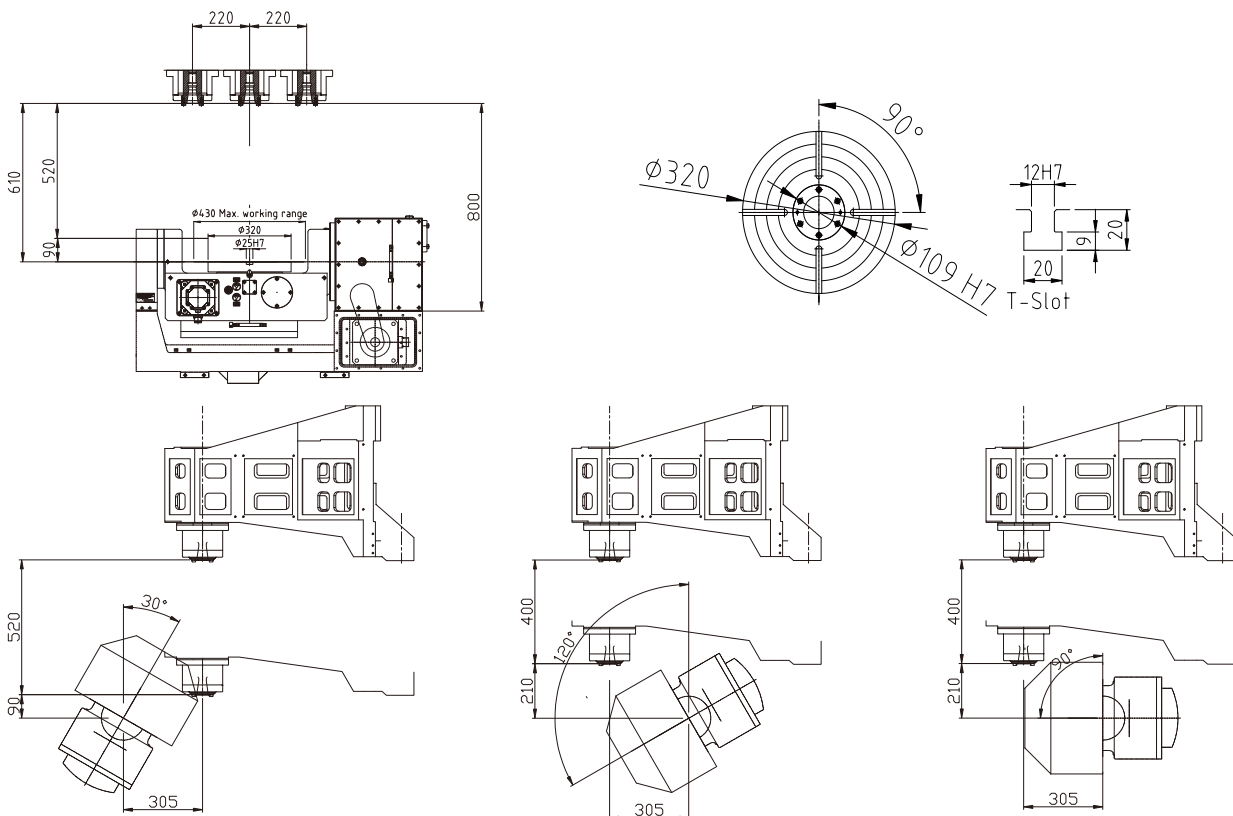

# Machine Specification

Travel	UC250x	UC320x
X/Y/Z-axis	360 / 520 / 610mm	440 / 610 / 520mm
Distance from spindle nose to table	65-675mm	90-610mm

Table	UC250x	UC320x
Dimension	φ250mm	φ320mm
Max. load	0°: 100kg / 90° :75kg	0°: 200kg / 90° :100kg
T-slot	N°4 WIDTH 12 - 90°	N°4 WIDTH 12-90°

Spindle	UC250x	UC320x
Spindle type		Direct-drive
Spindle speed		15000rpm
Spindle motor power		9kW/15kW (Cont./S3-25%)
Spindle taper		BBT40

Feed	UC250x	UC320x
Rapid feed (X/Y/Z)		36/36/24m/min
Cutting feed		12000mm/min
Motor power (X/Y/Z)		3.0/4.0/4.0 kW

C-Axis	UC250x	UC320x
Rotary table diameter	φ250mm	φ320mm
Rotation range	360°	360°
Positioning accuracy	±5"	±5"
Rotation speed	33.3rpm	22.2rpm
Rotation torque	720Nm	720Nm

A-Axis	UC250x	UC320x
Rotation range	+30° ~ -120°	+30° ~ -120°
Positioning accuracy	±5"	±5"
Rotation speed	22.2rpm	16.7rpm
Rotation torque	1080Nm	1440Nm

ATC & Magazine	UC250x	UC320x
ATC type		Arm
Number of tools		24pcs
Max. tool diameter (next pockets empty)	75/120mm	75/150mm
Max. tool length		280mm
Max. tool weight		7kg
Tool shank		BBT40

Supply	UC250x	UC320x
Air pressure		6kgf/cm <sup>2</sup>
Electric power supply	40kVA	75kVA

Net weight	UC250x	UC320x
Machine weight	6700kg	7100kg

- The specifications and information may be changed without prior notice.

# Standard & Optional

● : Standard   ○ : Option   × : Non Applicable

Spindle		UC250x	UC320x
15,000rpm		●	●
<b>ATC</b>			
ATC Extension	24T	●	●
	32T	○	×
	40T	×	○
	60T	×	○
Tool Shank Type	BBT40	●	●
	HSK-63A	○	○
<b>Coolant System</b>			
Coolant Through Spindle		○	○
Air Through Spindle		●	●
Cutting Air Blast		●	●
Cutting Coolant System		●	●
<b>Chip Disposal</b>			
Coolant Tank & Coolant Flushing System		●	●
Full Chip Enclosure		●	●
Chip Disposal	Auger Type	●	●
	Steel Belt Type	○	○
	Scraper Type	○	○
<b>Feed Axes</b>			
Linear Scales (X/Y/Z)		○	○
A/C-Axis Rotary Encoder		●	●
<b>Electric Device</b>			
3-Color Signal light		●	●
Working Light		●	●
Air Conditioner for Electric Cabinet (HEIDENHAIN)		○	○
Heat Exchanger for Electrical Cabinet (Fanuc, Takumi)		●	●
<b>Measuring Device</b>			
Workpiece Measurement		○	○
Tool Measurement		○	○
<b>Environment</b>			
Oil Skimmer		●	●
Oil Mist Collector		○	○
Oil Mist Device		○	○
<b>Control</b>			
Fanuc 0iMF-Plus 10.4"		●	●
Fanuc 31iMB		○	○
Heidenhain TNC620		○	○
Takumi PC Console		○	○
<b>Transformer</b>			
Transformer 50KVA 60KVA 3P 380/415/440/220V		×	○
Transformer 60KVA 60KVA 3P 380/415/440/220V		○	×
<b>ITS™(INTELLIGENT THERMAL SUPERVISOR™)</b>			
i Spin-TC I™		○	○
<b>ETC</b>			
Spindle Grease Lubrication		●	●
Rotary Center Checkup Kits		○	○
Automatic Doors		○	○
Leveling Block and Screws		●	●
Maintenance Tools		●	●
Manuals		●	●
Washing Gun & Air Gun		●	●
Manual Pulse Generator		●	●
Transformer		○	○
Automatic Centralized Lubrication System		●	●
CE Certified		●	●

**TAKUMI** When Precision Matters

**TAKUMI**

No.10, Gong 10th Rd., Dajia Distr., Taichung City 437, Taiwan

T +886 4 26811215

F +886 4 26822803

sales-os@takumi.com.tw

www.takumi.com.tw



UC-01-EN-202202