

TAKUMI When Precision Matters

TAKUMI

H Series



TAKUMI

No.10, Gong 10th Rd., Dajia Distr., Taichung City 437, Taiwan

T +886 4 26811215

F +886 4 26822803

sales-os@takumi.com.tw

www.takumi.com.tw



High Speed Bridge Type
Machining Center

H6
H10
H12E
H16

SH-02-EN-202603

02 **Product Preview**

03 **Applications & Parts**

Basic Information

05 Basic Structure

07 Frame

09 Spindle

11 Spindle Thermal Compensation Technology

13 Feed Axis

15 Automatic Tool Changer

Machine Information

17 User Convenience

19 Diagrams

21 Machine Specification

22 Standard & Optional

CONTENTS



High rigidity frame structure

The solid one-piece bed, column and cross rail design with no weldments, provides excellent support. The base width provides stability for large table loads. Cross rail saddle carries a constant weight which results in excellent part finish at fast cutting speeds.

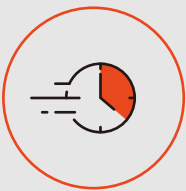

High speed, high accuracy

The H Series meet the requirement of high accuracy and high speed simultaneously thanks to the optimal mechanical structure, high response axial transmission system, low vibration and excellent thermal controlled spindle.

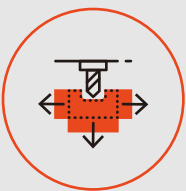

Largest Y-axis travel in its class

The H series large work envelope, which can machine large workpieces that are difficult to handle by other machines in the same class.

H Series

The Takumi H Series machining centers are designed for high dynamic and accuracy as demonstrated in both surface finish quality and consistent precision.





Applications & Parts

Basic Information

Machine Information

03 Applications & Parts

H Series

**Rigid and accurate
for every applications**

The H Series exceeds all of your expectations by providing high rigidity, high speed and maximum productivity. The one-piece bed structure coupled with the ladder design offers enhanced rigidity, while its impressive traverse rate guarantees ultimate productivity. Additionally, the larger work envelope provides greater opportunities for manufacturers in the die/mold, aerospace, automotive, and other industries.



Car Grille Shutter Mold



Bottle Mold

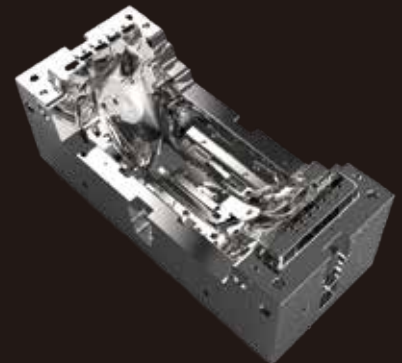

Car Bumper Mold



Scan
for more videos

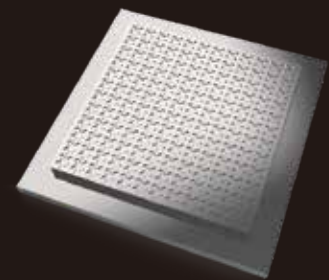

IC Tray

Basic Structure

01

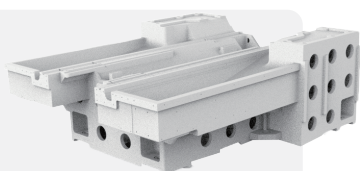

High rigidity frame structure

High rigidity one-piece bed, column and cross rail providing excellent stability as the casting absorbs the thrust forces of high rapids, while the "ladder" design of the cross rail, enables the spindle to be stable and powerful at high speeds.

02



High speed built-in spindle

The high-power built-in spindle limits vibration, noise and power loss during high speeds to achieve superior part finish. The helical cooling channel design minimizes thermal distortion and enables precision over extended cycle times.

03



Superior thermal control technology

Sophisticated thermal control system achieves precision despite variations in ambient temperature.

04

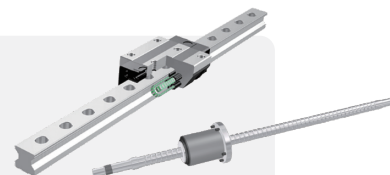

High speed, stable axis structure

The H Series are equipped with roller type LM guideways that offer the best combination of high speed and superior rigidity. High precision ballscrews are connected directly to axis motors.

05

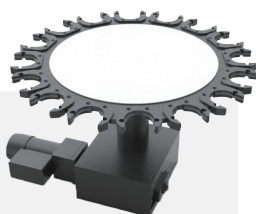

ATC and magazine

H Series offer a wide range of magazine capacity options, from 16 tools even up to 120 tools.

H Series

 **TAKUMI**

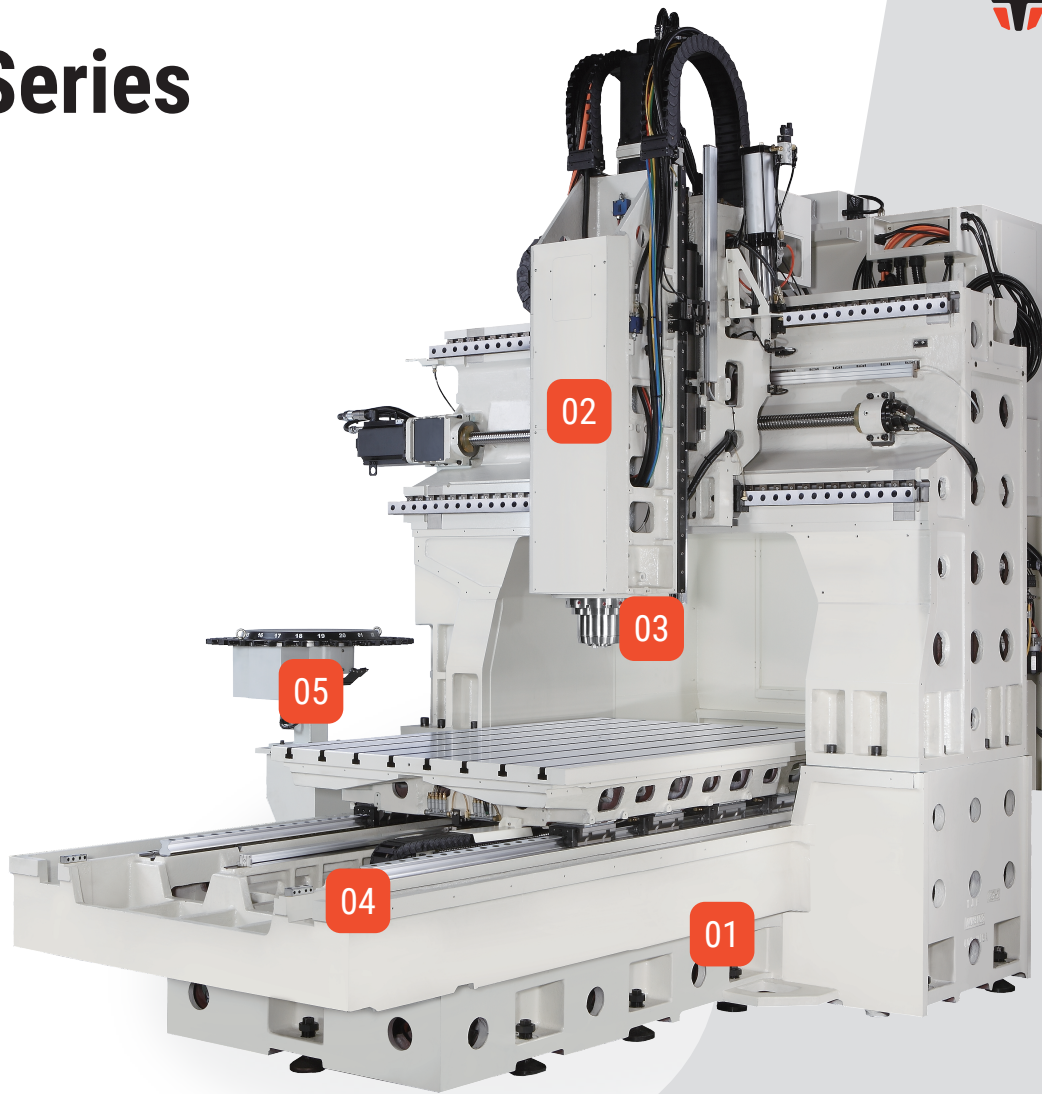

06 Basic Structure

H6

30/30/30

m/min Rapid traverse (X/Y/Z-axis)

600/600/350

mm Travel (X/Y/Z-axis)

H10

32/32/32

m/min Rapid traverse (X/Y/Z-axis)

1020/700/500

mm Travel (X/Y/Z-axis)

H12E

36/36/36

m/min Rapid traverse (X/Y/Z-axis)

1250/950/580

mm Travel (X/Y/Z-axis)

H16

30/30/30

m/min Rapid traverse (X/Y/Z-axis)

1600/1300/700

mm Travel (X/Y/Z-axis)

Applications and Parts

Basic Information

- Frame

Machine Information

07 Frame

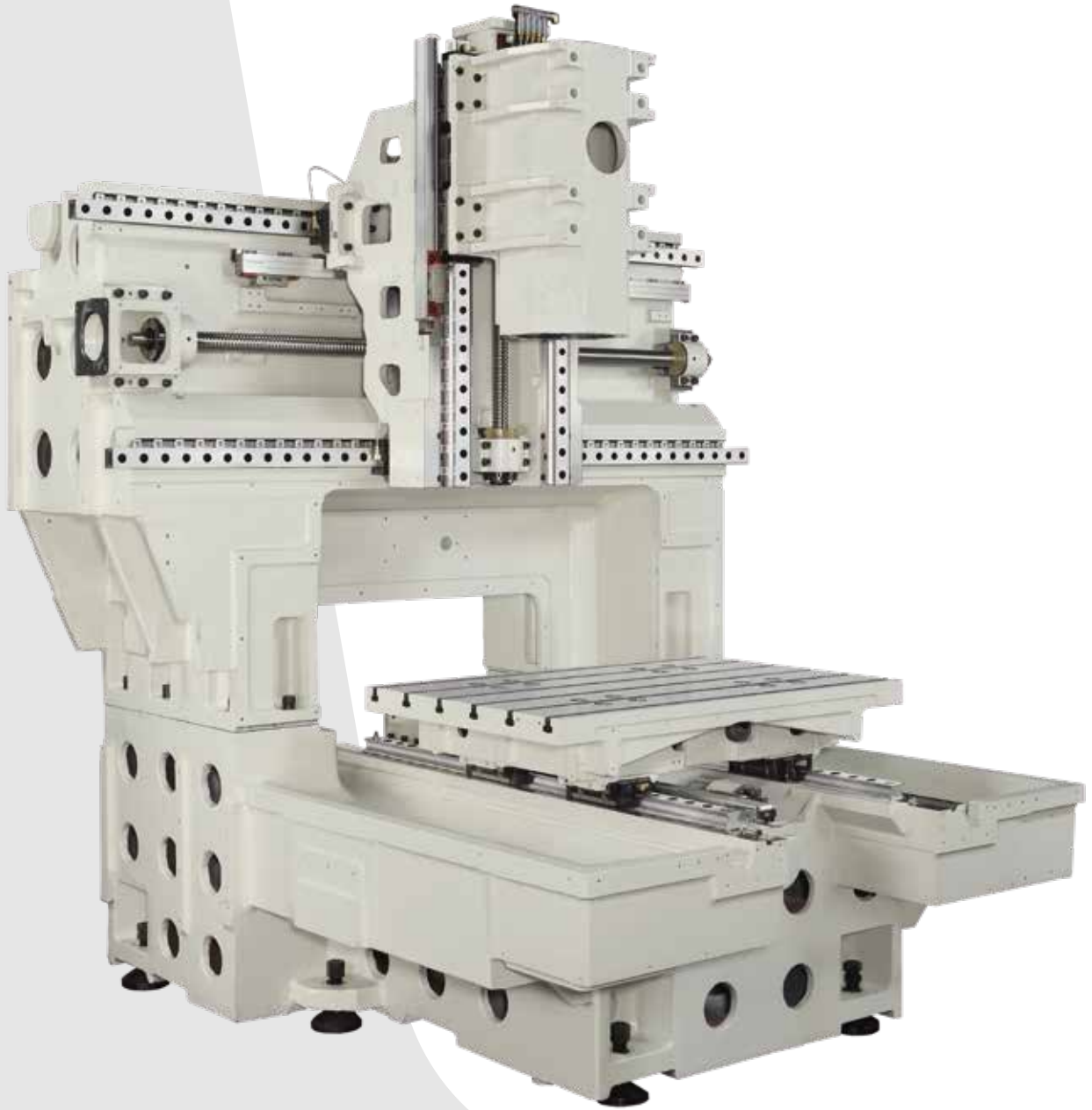

01

H Series
Frame



Robust one-piece casting bed

Integrated bed frame ensures high rigidity, excellent vibration absorption and outstanding surface finishes, especially when compared to separate structures.

The base width provides stability for heavy table loads even when operating at high speed.

Outstanding ladder structure on the beam

The bridge utilizes a "ladder design" head casting and saddle which increases rigidity, reduces overhang and eliminates head deflection. The Y-axis cross rail saddle carries a constant weight, allowing for faster cutting while maintaining excellent part finish.

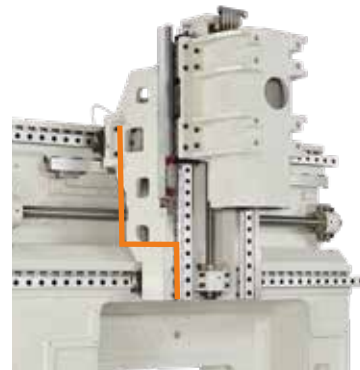

Double column structure

The one-piece design provides increased weight to absorb cutting vibration, and increased rigidity. The dual contact areas with the base eliminates pitch in the Y-axis and reduces the effect of machine leveling changes over time.

Hand scraping

Accuracy is ensured by hand scraped contact points. Contact surfaces such as column to base components, spindle cartridge to spindle housing, ball screw bearing block seats to bearing retainer and worktable to linear guide trucks and motor seat.

Hand scraping results in better mating surfaces of key components and will provide consistent results over a longer period of time.



02 H Series Spindle



High Speed Built-in Spindle

The high-power built-in spindle limits vibration, noise and power loss during high speeds to achieve superior part finish. The helical cooling channel design minimizes thermal distortion and enables precision over extended cycle times.

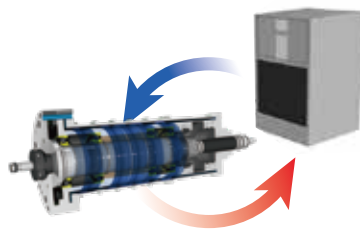

Stable Spindle Cooling Circulation

Spindle temperature is constantly controlled by oil chiller. Our test result have proven that the temperature of the circulating oil is controlled within $\pm 0.2^{\circ}\text{C}$. which minimizes thermal displacement during continuous operation at high speed.

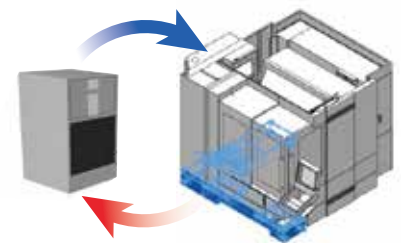

Cutting Coolant Chiller **option**

The coolant chiller reduces the temperature of the cutting fluid before it is circulated through the machine. The cooler has effectively reduced the deviation and leads to excellent accuracy of the workpieces and extends the life of cutting tool by stabilizing coolant temperature.

Spindle Power - Torque Curve

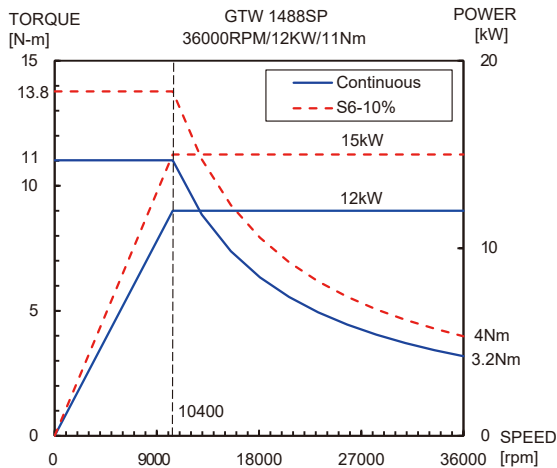

36,000rpm GTW Built-in spindle (ST:H6)
12/15 kW Power (Cont./S6-10%)
11/13.8 N.m Torque (Cont./S6-10%)

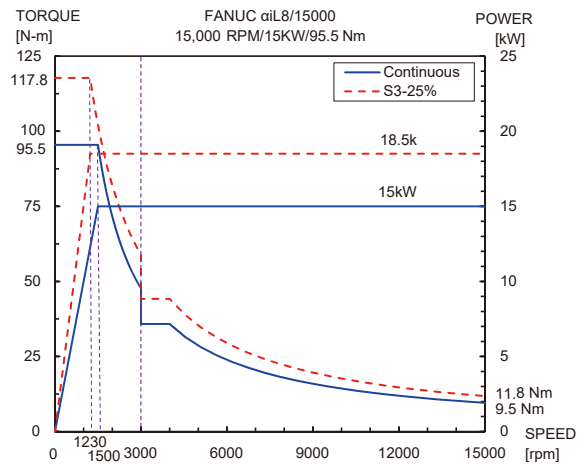

15,000rpm Direct drive spindle (ST:H10, H12E, H16)
15/18.5 kW Power (Cont./S3-25%)
95.5/117.8 N.m Torque (Cont./S3-25%)

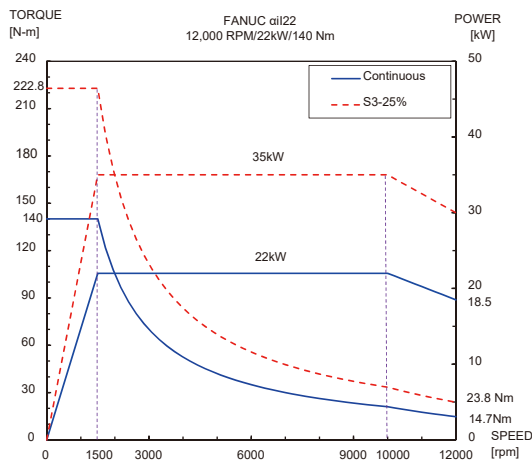

12,000rpm Direct drive spindle (OPT:H16)
22/35 kW Power (Cont./S3-25%)
140/222.8 N.m Torque (Cont./S3-25%)

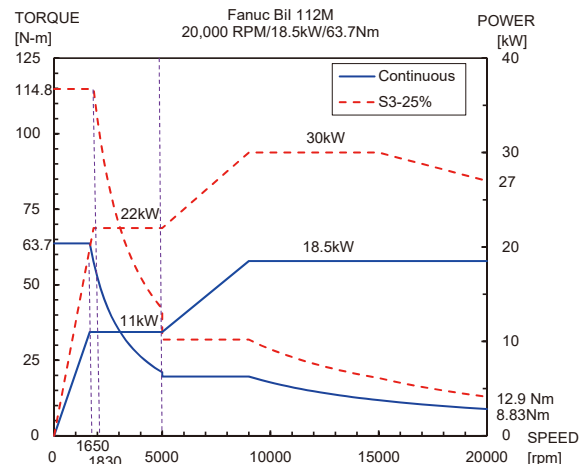

20,000rpm Built-in spindle (OPT:H10, H12E, H16)
18.5/30 kW Power (Cont./S3-25%)
63.7/114.8 N.m Torque (Cont./S3-25%)

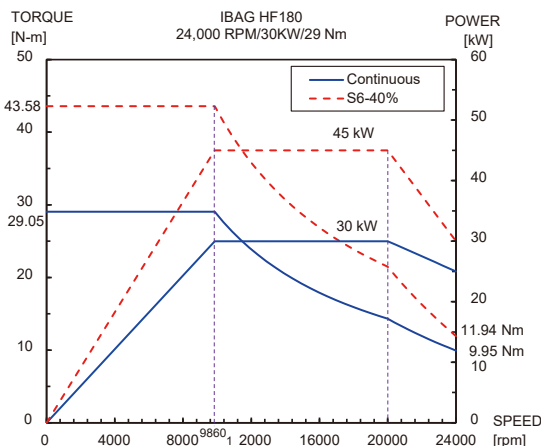

24,000rpm IBAG Built-in spindle (OPT:H10, H12E)
30/45 kW Power (Cont./S6-40%)
29.05/43.58 N.m Torque (Cont./S6-40%)

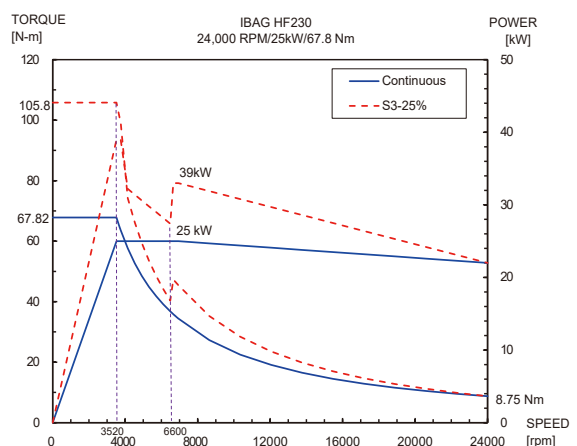

24,000rpm IBAG Built-in spindle (OPT:H16)
25/39 kW Power (Cont./S3-25%)
67.82/105.8 N.m Torque (Cont./S3-25%)

*Contact us for more spindle options.

03

H Series

Intelligent Spindle Thermal Compensation Technology

TAKUMI's unique spindle thermal compensation technology minimizes the heat and compensates for thermal expansion, which ensures better surface finish over extended cycle times.

Your benefits



Machine warm-up is not needed



High precision cutting performance is guaranteed



High processing stability over continuous runs



Save money and reduce the time and cost on cutting workpieces.

Deformation precisely controlled

There are several heat sources that can influence the performance of the machine tool. Three main thermal displacement sources are the spindle, the casting and the motors of axial drives. Among these sources, thermal deformation in the spindle and headstock is the most critical.

■ H10 with HEIDENHAIN TNC640; 15,000rpm direct drive; no machine warm up.

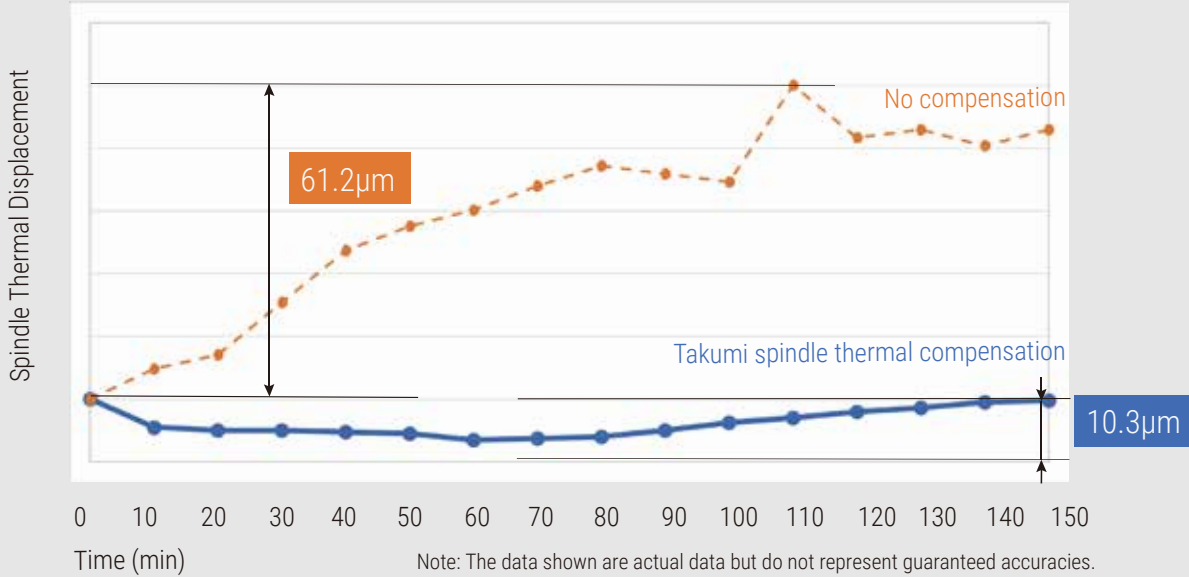

Spindle Thermal Compensation Real Cutting

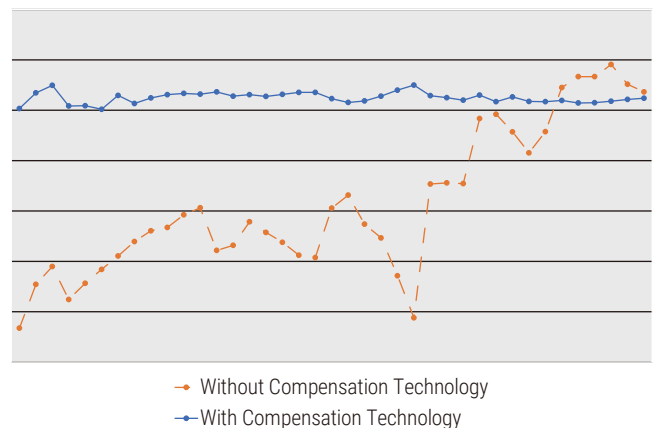
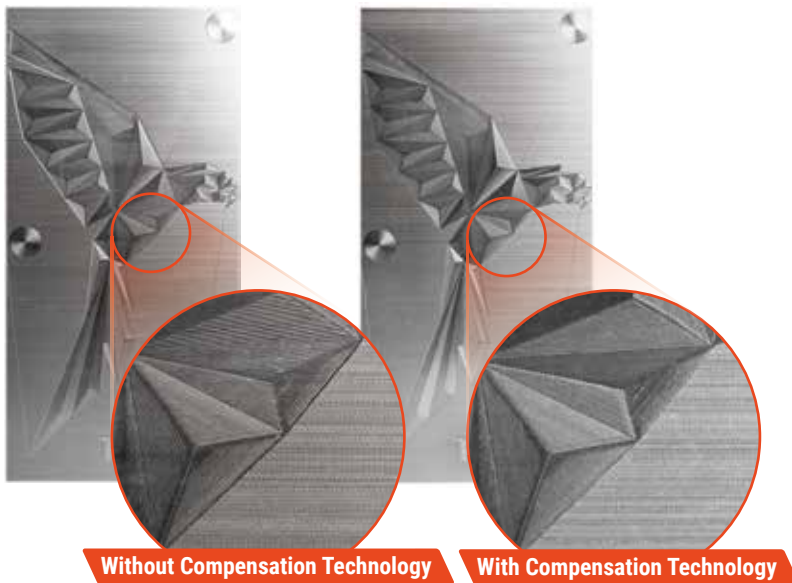

The edges between each areas are obvious before compensation. Whereas the edges on the workpiece after compensation are not obvious because the error is much smaller.

When using Takumi spindle thermal compensation, thermal deformation is less than 5µm (real cutting results).

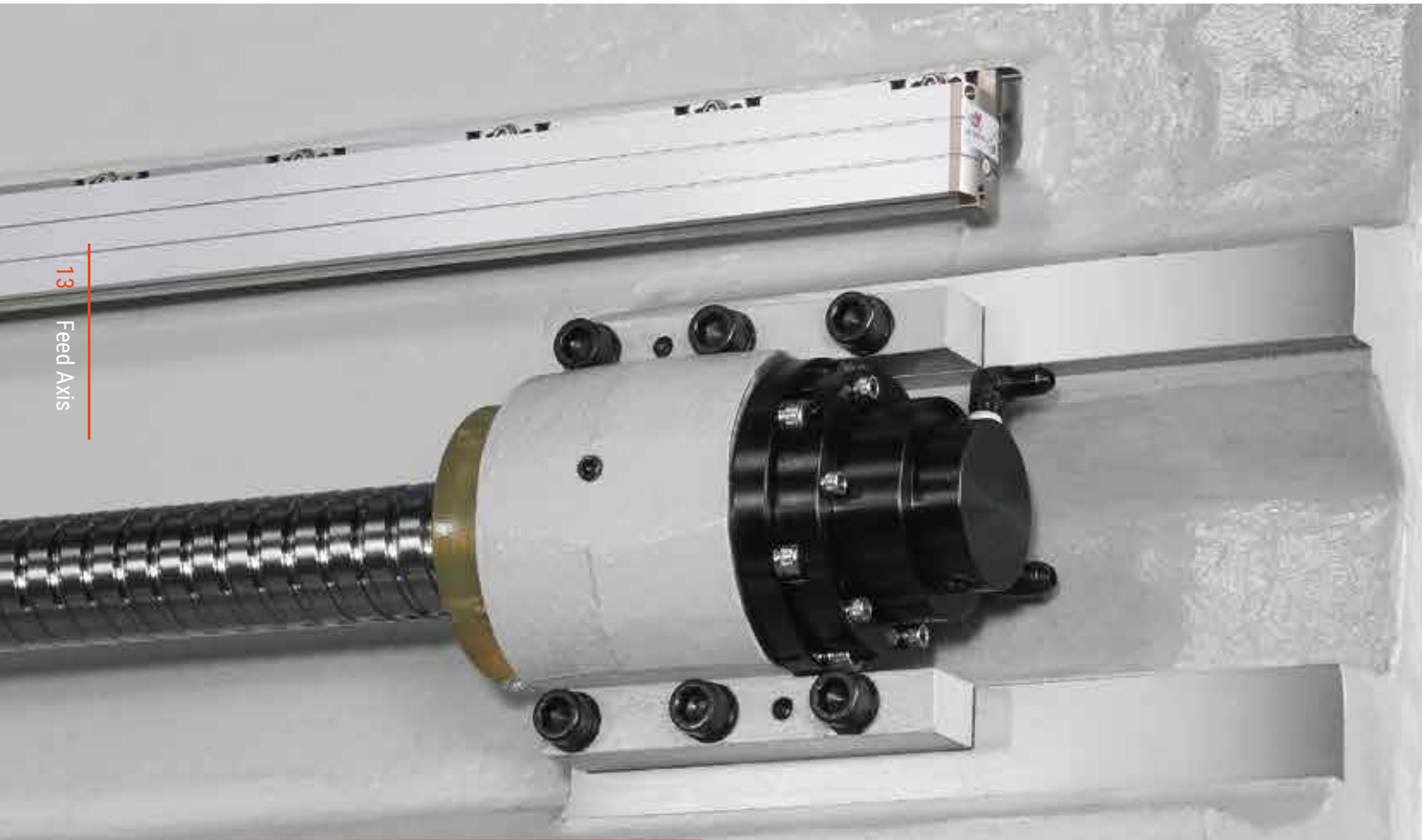

04 H Series Feed Axis

H6 **30/30/30**
m/min Rapid traverse rate (X/Y/Z-axis)

H12E **36/36/36**
m/min Rapid traverse rate (X/Y/Z-axis)

H10 **32/32/32**
m/min Rapid traverse rate (X/Y/Z-axis)

H16 **30/30/30**
m/min Rapid traverse rate (X/Y/Z-axis)



Double Anchored Ballscrew

To eliminate lost motion, the ballscrews are anchored on both ends and pre-tensioned. The motors are directly coupled to the ballscrews.

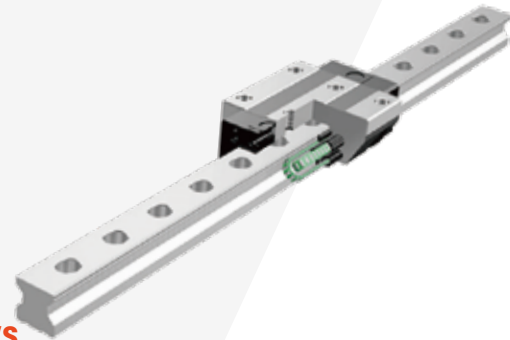

Roller Type LM Guideways

All axes are equipped with LM roller guideways. These features higher load capacity and greater rigidity even at high acceleration. Additionally, they have greater contact area to support faster feeds, higher rigidity and higher weight bearing capability.

Larger Ballscrew

H series are equipped with high precision ballscrews, featuring high load capacity while also providing high durability and rigidity.

Oversize Ø45 mm (H10 X-axis) ballscrews provide rigidity and accuracy during heavy cutting.

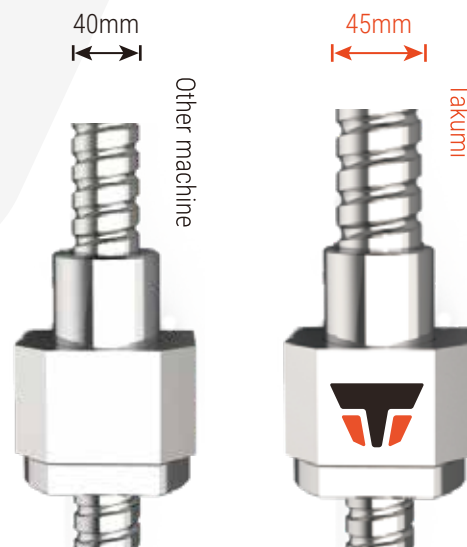

High Accuracy Linear Scales

Linear scales are standard on all 3 axes. Mounted to the table, cross rail and head they take a direct reading of the true position of the axes. This compensates for thermal growth of the ballscrews mechanical flex and backlash, for improved accuracy and repeatability during the life of the machine.



ATC

The ATC is mounted outside of the work area, with a door protecting the mechanisms of the tool changer, keeping tools and tool changer from chips and coolant.



Tool magazine for various types of tools

The tool magazine can store up to 16 (H10, H12E) and 20 (H6, H16) as standard and up to maximum 120 as option depending on the model. Optional servo driven magazine ensures fast and reliable tool indexing.

05 H Series Automatic Tool Changer

Maximum workpiece weight

H6	500 kg	H12E	2000 kg
H10	800 kg	H16	6000 kg

Maximum workpiece size (L x W x H)

H6	600 x 600 x 350mm
H10	700 x 1020 x 420mm
H12E	950 x 1250 x 550mm
H16	1300 x 1600 x 750mm

Maximum workpiece size (L x W x H)

H10 provides 88% more space for larger workpieces in its class.

Other machine	500 x 1000 x 450mm
H10	700 x 1020 x 420mm

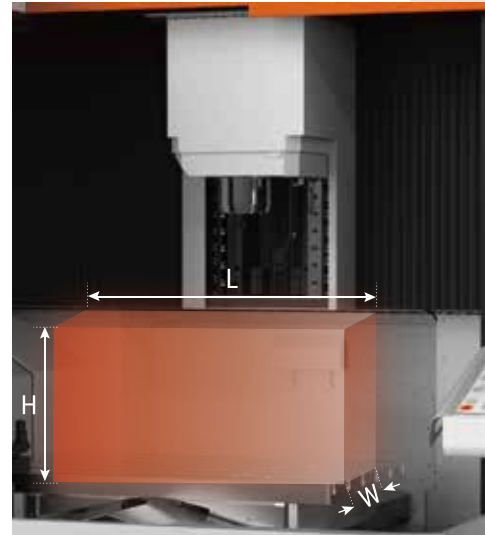

Other machine



★ Takumi H10



200mm more
on Y-travel

The H series are built ergonomically for simple operation and uncomplicated maintenance.



01 Optimal Ergonomic Design

The operation panel can swivel 120°, and the height can be adjusted to the operator's viewpoint.

02 Two Doors Opening

Large door opening to the working area gives the operator impressive freedom and handling space.

H6 1050+890
mm width of the door

H10 1240+690
mm width of the door

06

**H Series
User Convenience**

Ergonomic Design

Closer access to the table makes setup work such as fixture adjustment and maintenance easy.

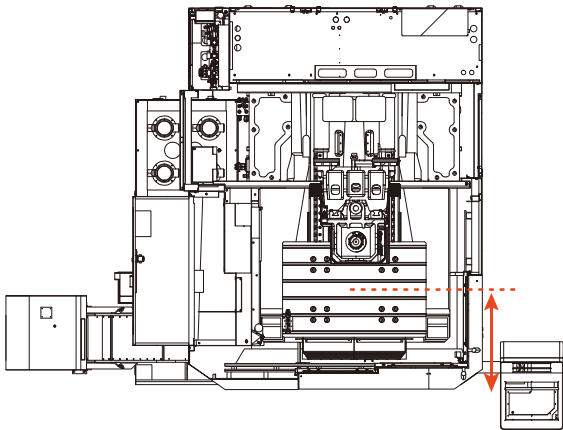

▪ **Distance to the center of the table:**

- 617mm (H6)
- 727mm (H10)
- 615mm (H12E)
- 949mm (H16)

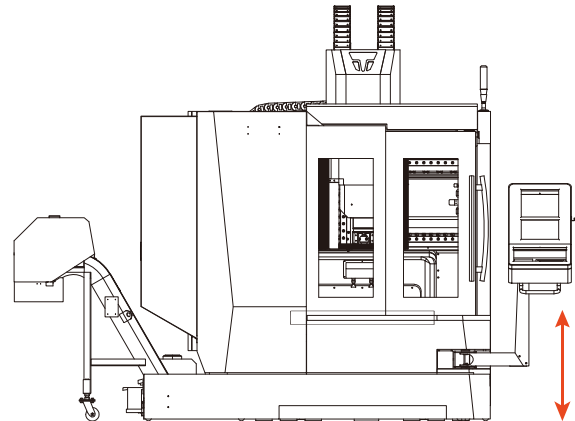

▪ **Distance from floor surface to table top:**

- 735mm (H6)
- 805mm (H10)
- 725mm (H12E)
- 930mm (H16)

Rear Side Flushing Coolant System

The design of the sloping way covers, tilt of the bed casting and the flushing coolant system on H10 provides excellent chip removal.



Dual Chip Auger

Chip removal efficiency is greatly enhanced thanks to the dual screw type augers on H12E and H16.

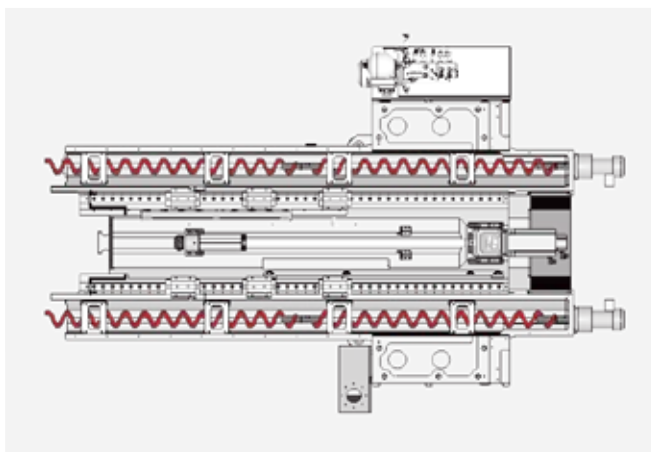

Effective Chip Removal Solutions

High pressure coolant and/or air through the spindle and other chip removal solutions help wash away chips from hole drilling, tapping and other machining. By effectively cooling and flushing, tool life can be greatly extended.



Air through spindle

Spindle cooling splash



30 bar coolant through spindle

External Dimension

H6

Unit : mm

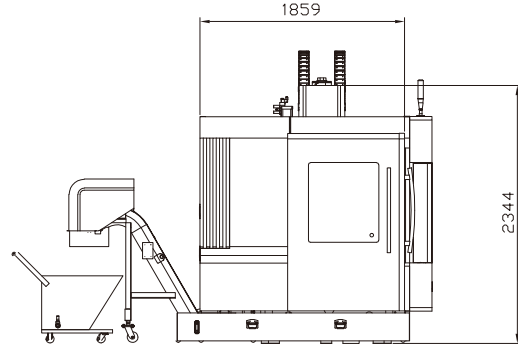
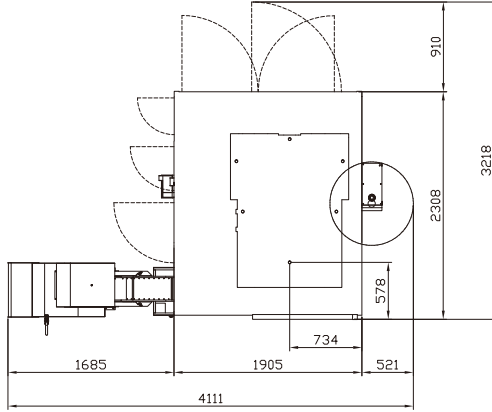

H10

Unit : mm

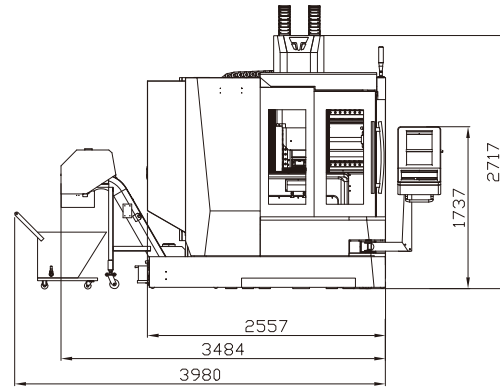
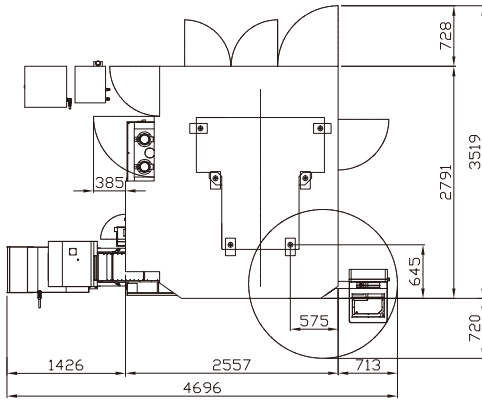

H12E

Unit : mm

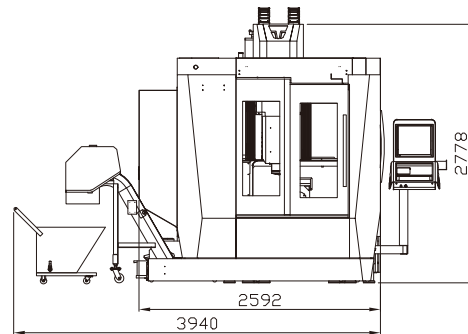
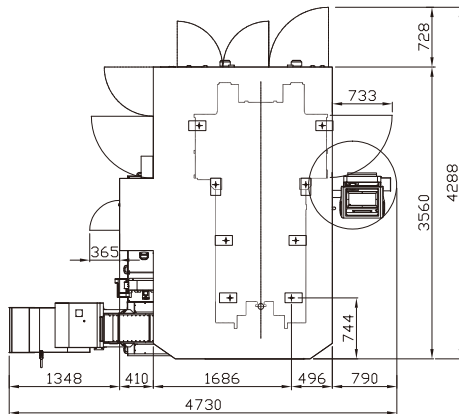

H16

Unit : mm

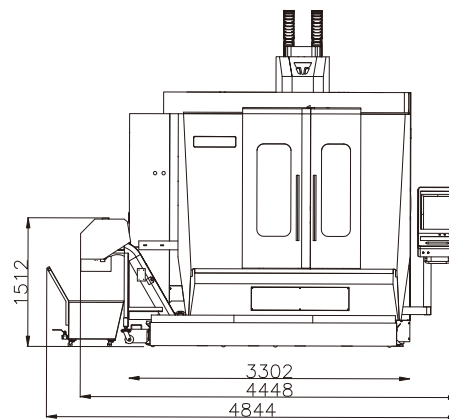
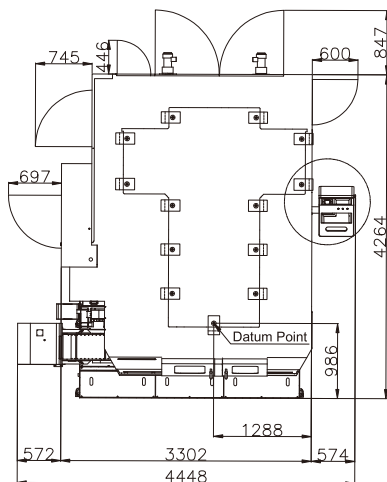
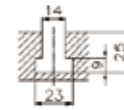
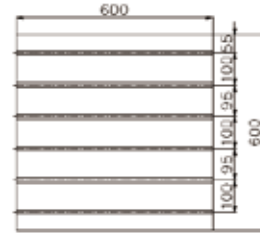
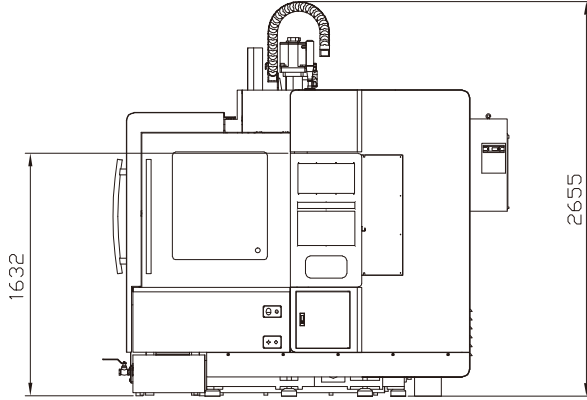

Table & T-Slot Dimension

Unit : mm

H6



Unit : mm

H10

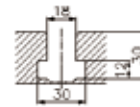
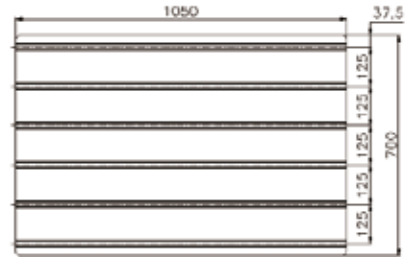
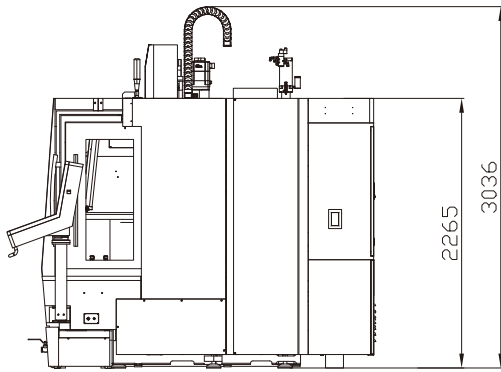

Unit : mm

H12E

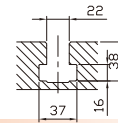
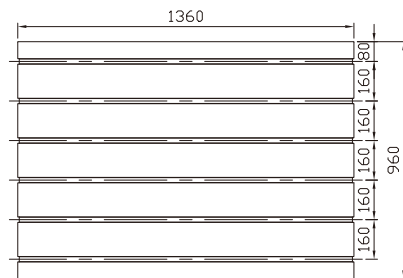
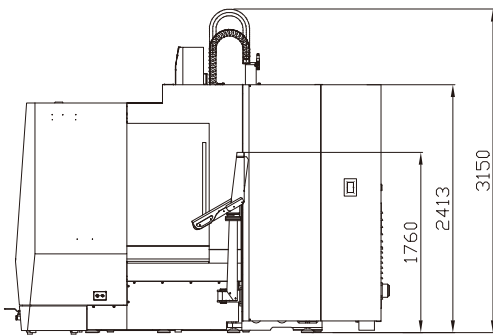

Unit : mm

H16

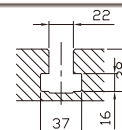
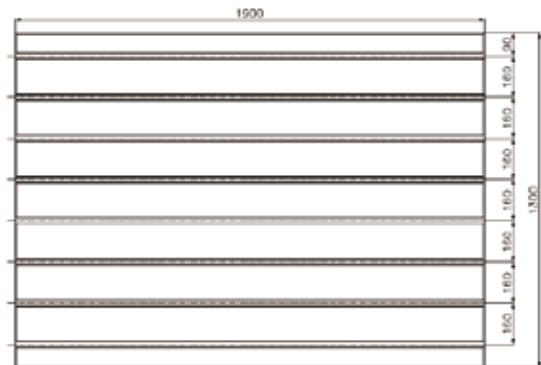
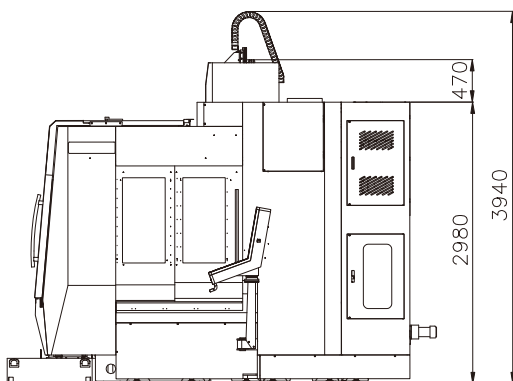

Machine Specification

Travel	H6	H10	H12E	H16
X/Y/Z-axis	600 / 600 / 350mm	1020 / 700 / 500mm	1250 / 950 / 580mm	1600 / 1300 / 700mm
Distance from spindle nose to table	120-470mm	180-680mm	200-780mm	160-860mm
Distance between columns	680mm	1080mm	1060mm	1500mm

Table

Dimension	600 x 600mm	1050 x 700mm	1360 x 960mm	1900 x 1300mm
Max. load	500kg	800kg	2000kg	6000kg
T-slot (width x pitch x number)	14 x 100 x 6mm	18 x 125 x 6mm	22 x 160 x 6mm	22 x 160 x 8mm

Spindle

Spindle type	Built-in	Direct-drive
Spindle speed	36000 rpm	15000 rpm
Spindle motor power	12 kW/15 kW (Cont./S6-10%)	15 kW/18.5 kW (Cont./S3-25%)
Spindle taper	HSK-E40	BBT40

Feed

Rapid feed (X/Y/Z)	30/30/30m/min	32/32/32m/min	36/36/36m/min	30/30/30m/min
Cutting feed			20000mm/min	
Motor power (X/Y/Z)	1.6/1.6/3.0kW	4.5/4.5/4.5kW	7.0/4.0/4.0kW	9.0/6.0/6.0kW

ATC & Magazine

ATC type		Armless		
Number of tools	20	16	16	20
Max. tool diameter (next pockets empty)	75/100mm	105/120mm	105/120mm	120/150mm
Max. tool length	200mm		270mm	300mm
Max. tool weight	1.5kg	3kg	3kg	7kg
Tool shank	HSK-E40		BBT40	

Supply

Air pressure			6kgf/cm ²	
Electric power supply	30kVA	50kVA	60kVA	75kVA

Net Weight

Machine weight	5500kg	9100kg	10570 kg	20000kg
----------------	--------	--------	----------	---------

* The specifications and information may be changed without prior notice.

Standard & Optional

● : Standard ○ : Option × : Non Applicable

Spindle		H6	H10	H12E	H16
10,000rpm		×	×	×	×
12,000rpm		×	×	×	○
15,000rpm		×	●	●	●
20,000rpm		×	○	○	○
24,000rpm		×	○	○	○
36,000rpm		●	○	×	×
42,000rpm		○	×	×	×
ATC					
ATC Extention*	16T	×	●	●	×
	20T	●	×	×	●
	30T	×	○	○	○
	32T	×	×	×	○
Tool Shank Type	BBT40	×	●	●	●
	BBT50	×	×	×	○
	HSK-E40	●	×	×	×
	HSK-E50	×	○	○	×
	HSK-A63	×	○	○	○
	HSK-A100	×	×	×	○
*For more tool options, please contact us.					
Coolant System					
Coolant Through Spindle Ready (without filter)		×	○	○	○
Coolant Through Spindle	30bar	×	○	○	○
	70bar	×	○	○	○
Air Through Spindle (without CTS)		×	○	○	○
Cutting Air Blast		●	●	●	●
Cutting Coolant Chiller		○	○	○	○
Chip Disposal					
Coolant Tank & Coolant Flushing System		●	●	●	●
Full Chip Enclosure		●	●	●	●
Chip Disposal	Tank	●	●	×	×
	Auger Type	○	○	●	×
	Steel Belt Type	○	○	○	●
	Scraper Type	○	○	○	○
Feed Axis					
Linear Scales (X/Y/Z)		●	●	●	●
3-Axis Absolute Encoder Motors		●	●	●	●
3-Axis Ballscrew Cooling		×	○	○	○
Electric Device					
3-Color Signal Light		●	●	●	●
Working Light		●	●	●	●
Air Conditioner for Electric Cabinet		●	●	●	●
Measuring Device					
Workpiece Measurement		○	○	○	○
Tool Measurement		○	○	○	○
Environment					
Oil Skimmer		●	●	●	●
Oil Mist Collector		○	○	○	○
Oil Mist Cutting Device		○	○	○	○
Control					
Fanuc OiMF-Plus Type 0, 15"		●	●	●	●
Siemens One, 15"		○	○	○	○
Heidenhain TNC7, 24"		○	○	○	○
Mitsubishi M830VS, 15"		○	○	○	○
ITS™(INTELLIGENT THERMAL SUPERVISOR™)					
iSpin-TC I™		○	○	○	○
iSpin-TC II™		○	○	○	○
iSpin-TC III™		○	○	○	○
ETC					
Safety Doorlock		●	●	●	●
Leveling Block and Screws		●	●	●	●
Maintenance Tools		●	●	●	●
Manuals		●	●	●	●
Washing Gun & Air Gun		●	●	●	●
Manual Pulse Generator (MPG)		●	●	●	●
USB / Ethernet / RS-232C Interface		●	●	●	●
Automatic Centralized Lubrication System		●	●	●	●
CE Certified		○	○	○	○